

# REB-300 BIG

## SLICER FOR HAM AND CHEESE 12".



### FEATURES

- Manual gravity-fed slicer.
- Stainless steel blade.
- Powered by a highly durable belt.
- Motor with built-in fan blade to dissipate heat.



This unit comes with a NEMA 5-15P plug.

### SPECIFICATIONS



Model	Ø Blade	Motor	Electrical	Cutting Cross Section	Cutting thickness	Food Chute
	Plg	Hp	Vol/Hz	Plg	Plg	Plg
300 BIG	12"	0,33	110/60	8,2 - 9	0 - 0,6	10,2



#### Adjustable slice size

The thickness of the cut can be easily adjusted.



#### Built-in sharpener

Dual-operation integrated sharpener for sharpening and honing.



#### Durable construction

Made with durable stainless steel and anodized aluminum.



# REB-300 BIG

SLICER FOR HAM AND CHEESE 12".

## DIMENSIONS

Weight: 39,6 Lb

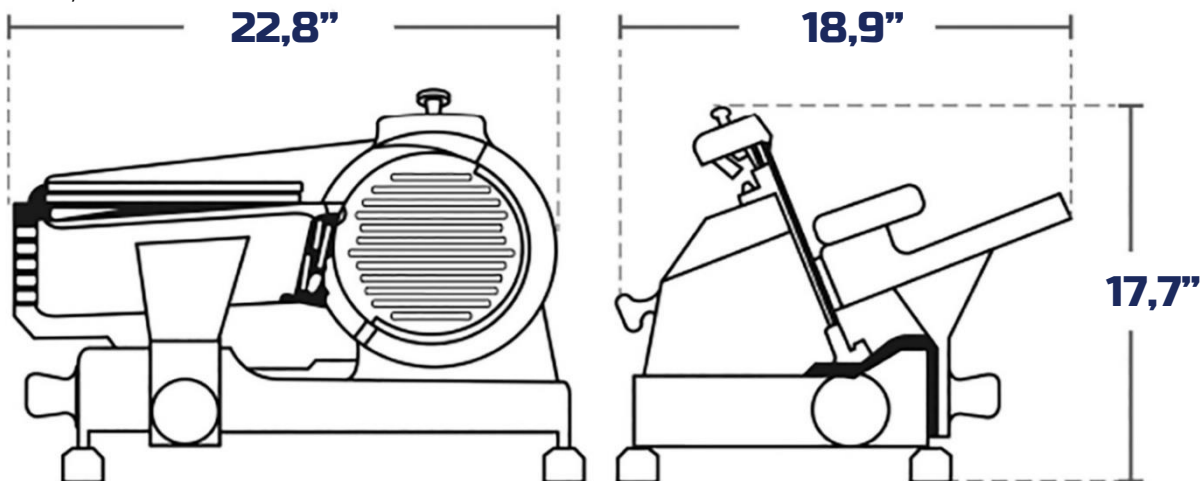

### FOR SLICING PIECES UP TO:



REB-12" BIG  
8,2" – 9"



REB-12" BIG  
Ø 8,2"

## PACKING DIMENSION

High	Width	Large	Weight
18"	21,6"	24,8"	51,8 Lb

## ADVANTAGES

- Time and money savings. Most parts of the Slicers can be easily disassembled without the need for tools, reducing the time spent on cleaning and maintenance costs.
- Highly hygienic and easy to clean, built with very durable aluminum giving it an excellent presentation to the equipment.
- Ideal for medium volume operations, this compact space-saving unit fits perfectly in kitchens with limited space.
- Nominal usage capacity of 25 minutes continuous use, 15 minutes rest, qualified for medium-high volume applications.
- All parts in contact with food are made with certified materials.