

# REB-195

SLICER FOR HAM AND CHEESE 8".



## FEATURES

- Manual gravity-fed slicer.
- Stainless steel blade.
- Powered by a highly durable belt.
- Motor with built-in fan blade to dissipate heat.



This unit comes with a NEMA 5-15P plug.

## SPECIFICATIONS



Model	Ø Blade	Motor	Electrical	Cutting Cross Section	Cutting thickness	Food Chute
	Plg	Hp	Vol/Hz	Plg	Plg	Plg
195	8"	0,15	110/60	5 - 7	0 - 0,4	8



### Adjustable slice size

The thickness of the cut can be easily adjusted.



### Efficiency

Includes dual-operation sharpener for sharpening and honing.



### Durable construction

Made with durable stainless steel and anodized aluminum.



# REB-195

SLICER FOR HAM AND CHEESE 8".

## DIMENSIONS

Weight: 19 Lb

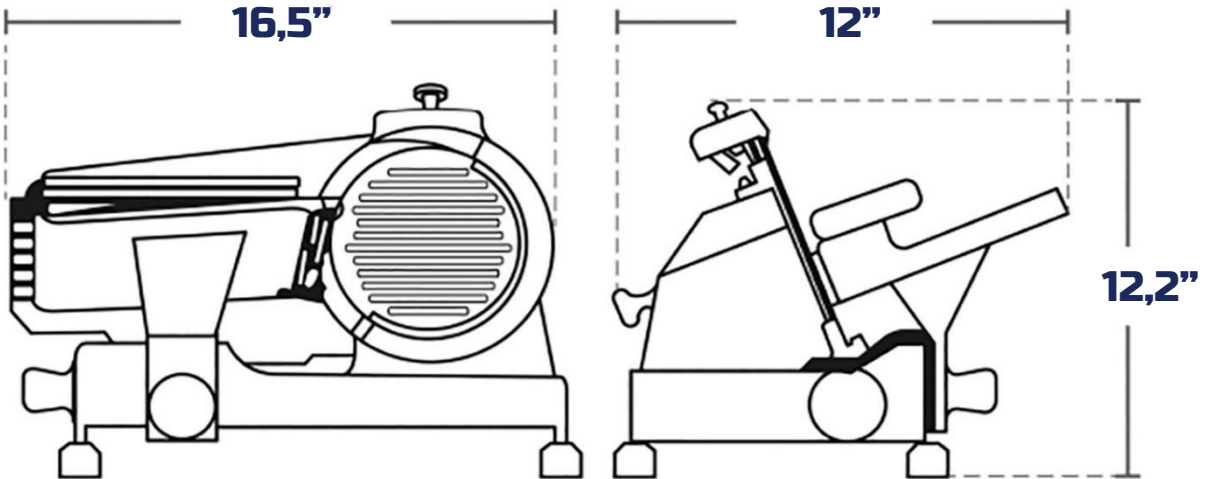

### FOR SLICING PIECES UP TO:



REB-8"  
6" x 7,8"



REB-8"  
Ø 6"

## PACKING DIMENSION

High	Width	Large	Weight
13"	13"	17,7"	22,5 Lb

## ADVANTAGES

- Time and money savings. Most parts of the Slicers can be easily disassembled without the need for tools, reducing the time spent on cleaning and maintenance costs.
- Highly hygienic and easy to clean, built with very durable aluminum giving it an excellent presentation to the equipment.
- Thanks to its compact dimensions, this cutter fits even in the smallest kitchens.
- Nominal capacity of use from 3 to 4 hours daily. Rated for medium volume applications.
- All parts in contact with food are made with certified materials.